



# PCB Supports - LTP Series

561-LT187, 561-LT250, 561-LT375, 561-LT437,  
 561-LT500, 561-LT625, 561-LT750, 561-LT875,  
 561-LT1000, 561-LT1125, 561-LT1250

**Date Last Revised: 11-27-06**

Circuit Board Supports eliminate screws, nuts, and lockwashers in mounting printed circuit boards on metal chassis or stacking in multiple tiers. Unique locking designs provide mechanically secure, reusable connection in predrilled or punched holes while saving considerable assembly time and expense.

The LTP Series is designed to securely lock to the bottom chassis and snap into the top board.

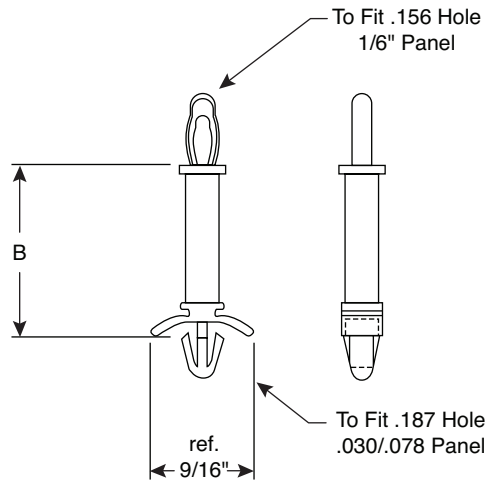

Item Number	Description	B in. (mm)
561-LT187	3/16" Lock/Tension	0.307 (7.80)
561-LT250	1/4" Lock/Tension	0.365 (9.27)
561-LT375	3/8" Lock/Tension	0.495 (12.57)
561-LT437	7/16" Lock/Tension	0.557 (14.15)
561-LT500	1/2" Lock/Tension	0.625 (15.88)
561-LT625	5/8" Lock/Tension	0.745 (18.92)
561-LT750	3/4" Lock/Tension	0.87 (22.09)
561-LT875	7/8" Lock/Tension	0.995 (25.27)
561-LT1000	1" Lock/Tension	1.12 (28.45)
561-LT1125	1 1/8" Lock/Tension	1.245 (31.62)
561-LT1250	1 1/4" Lock/Tension	1.37 (34.80)

**Available from Mouser Electronics**  
**1-800-346-6873**  
**www.mouser.com**

EPD-2000457